

PRODUCT INFORMATION PACKET

Model No: 326TSTDR16035
Catalog No: U446A
50,1800,DP,326TSC,3/60/230/460 PWS/YD
Open Drip Proof (ODP)



Regal and Marathon are trademarks of Regal Beloit Corporation or one of its affiliated companies.
©2018 Regal Beloit Corporation, All Rights Reserved. MC017097E

Nameplate Specifications

Output HP	50 Hp	Output KW	37.0 kW
Frequency	60 Hz	Voltage	230/460 V
Current	121.0/60.5 A	Speed	1775 rpm
Service Factor	1.15	Phase	3
Efficiency	94.5 %	Duty	Continuous
Insulation Class	B	Design Code	B
KVA Code	G	Frame	326TSC
Enclosure	Drip Proof	Overload Protector	No
Ambient Temperature	40 °C	Drive End Bearing Size	6312
Opp Drive End Bearing Size	6311	UL	Recognized
CSA	Y	CE	Y
IP Code	22		

Technical Specifications

Electrical Type	Squirrel Cage Induction Run	Starting Method	Part Wdg Start Low Volt Only & Wye Start Delta Run
Poles	4	Rotation	Reversible
Mounting	Rigid base	Motor Orientation	Horizontal
Drive End Bearing	Ball	Opp Drive End Bearing	Ball
Frame Material	Rolled Steel	Shaft Type	TS
Overall Length	27 in	Frame Length	15.00 in
Shaft Diameter	1.875 in	Shaft Extension	3.5 in
Assembly/Box Mounting	F1/F2 Capable		
Outline Drawing	A-SS301384-1500	Connection Diagram	A-EE7308AA

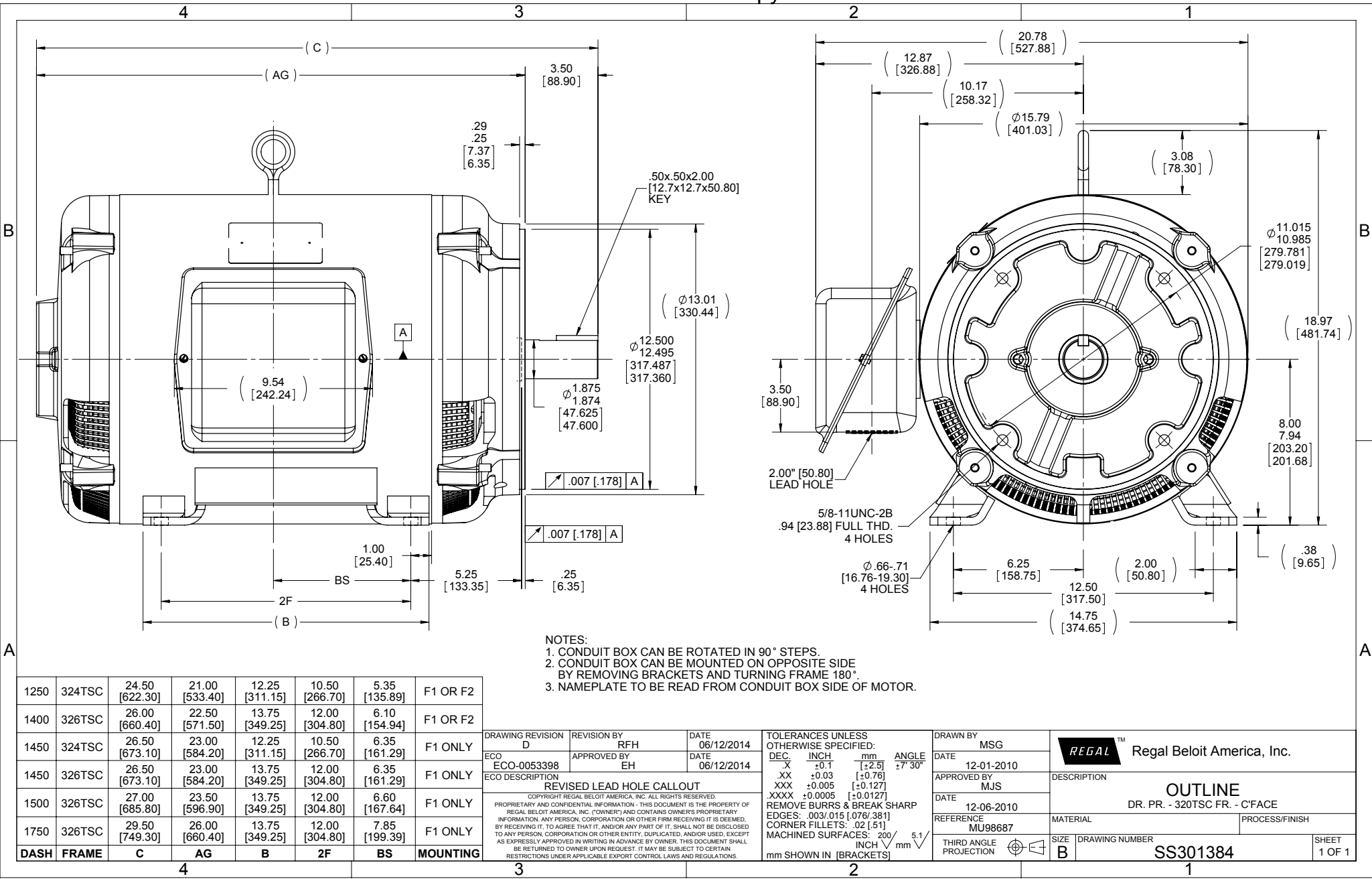

- NOTES:
 1. CONDUIT BOX CAN BE ROTATED IN 90° STEPS.
 2. CONDUIT BOX CAN BE MOUNTED ON OPPOSITE SIDE BY REMOVING BRACKETS AND TURNING FRAME 180°.
 3. NAMEPLATE TO BE READ FROM CONDUIT BOX SIDE OF MOTOR.

1250	324TSC	24.50 [622.30]	21.00 [533.40]	12.25 [311.15]	10.50 [266.70]	5.35 [135.89]	F1 OR F2
1400	326TSC	26.00 [660.40]	22.50 [571.50]	13.75 [349.25]	12.00 [304.80]	6.10 [154.94]	F1 OR F2
1450	324TSC	26.50 [673.10]	23.00 [584.20]	12.25 [311.15]	10.50 [266.70]	6.35 [161.29]	F1 ONLY
1450	326TSC	26.50 [673.10]	23.00 [584.20]	13.75 [349.25]	12.00 [304.80]	6.35 [161.29]	F1 ONLY
1500	326TSC	27.00 [685.80]	23.50 [596.90]	13.75 [349.25]	12.00 [304.80]	6.60 [167.64]	F1 ONLY
1750	326TSC	29.50 [749.30]	26.00 [660.40]	13.75 [349.25]	12.00 [304.80]	7.85 [199.39]	F1 ONLY
DASH	FRAME	C	AG	B	2F	BS	MOUNTING

DRAWING REVISION D	REVISION BY RFH	DATE 06/12/2014
ECO ECO-0053398	APPROVED BY EH	DATE 06/12/2014
ECO DESCRIPTION REVISED LEAD HOLE CALLOUT		
<small>COPYRIGHT REGAL BELOIT AMERICA, INC. ALL RIGHTS RESERVED. PROPRIETARY AND CONFIDENTIAL INFORMATION - THIS DOCUMENT IS THE PROPERTY OF REGAL BELOIT AMERICA, INC. (OWNER) AND CONTAINS OWNER'S PROPRIETARY INFORMATION. ANY PERSON, CORPORATION OR OTHER FIRM RECEIVING IT IS DEEMED, BY RECEIVING IT, TO AGREE THAT IT, AND/OR ANY PART OF IT, SHALL NOT BE DISCLOSED TO ANY PERSON, CORPORATION OR OTHER ENTITY, DUPLICATED, AND/OR USED, EXCEPT AS EXPRESSLY APPROVED IN WRITING IN ADVANCE BY OWNER. THIS DOCUMENT SHALL BE RETURNED TO OWNER UPON REQUEST. IT MAY BE SUBJECT TO CERTAIN RESTRICTIONS UNDER APPLICABLE EXPORT CONTROL LAWS AND REGULATIONS.</small>		

TOLERANCES UNLESS OTHERWISE SPECIFIED:		
DEC.	INCH	mm
.X	±0.1	[±2.5]
.XX	±0.03	[±0.76]
.XXX	±0.005	[±0.127]
.XXXX	±0.0005	[±0.0127]
REMOVE BURRS & BREAK SHARP EDGES: .003/.015 [.076/.381] CORNER FILLETS: .02 [.51] MACHINED SURFACES: .200 [5.1] mm SHOWN IN [BRACKETS]		

DRAWN BY MSG	DATE 12-01-2010
APPROVED BY MJS	DATE 12-06-2010
REFERENCE MU98687	
THIRD ANGLE PROJECTION	

Regal Beloit America, Inc.	
DESCRIPTION OUTLINE DR. PR. - 320TSC FR. - C'FACE	
MATERIAL	PROCESS/FINISH
SIZE B	DRAWING NUMBER SS301384
	SHEET 1 OF 1



LOW VOLTAGE



HIGH VOLTAGE



VIEW OF TERMINAL END

DRAWING REVISION K	REVISION BY AJW	DATE 07-17-2015
ECO ECO-0081632	APPROVED BY T. VUE	DATE 07-17-2015
ECO DESCRIPTION REV'D IEC MARKINGS PER IEC 60034-8		
COPYRIGHT REGAL BELOIT AMERICA, INC. ALL RIGHTS RESERVED. PROPRIETARY AND CONFIDENTIAL INFORMATION - THIS DOCUMENT IS THE PROPERTY OF REGAL BELOIT AMERICA, INC. ("OWNER") AND CONTAINS OWNER'S PROPRIETARY INFORMATION. ANY PERSON, CORPORATION OR OTHER FIRM RECEIVING IT IS DEEMED, BY RECEIVING IT, TO AGREE THAT IT, AND/OR ANY PART OF IT, SHALL NOT BE DISCLOSED TO ANY PERSON, CORPORATION OR OTHER ENTITY, DUPLICATED, AND/OR USED, EXCEPT AS EXPRESSLY APPROVED IN WRITING IN ADVANCE BY OWNER. THIS DOCUMENT SHALL BE RETURNED TO OWNER UPON REQUEST. IT MAY BE SUBJECT TO CERTAIN RESTRICTIONS UNDER APPLICABLE EXPORT CONTROL LAWS AND REGULATIONS.		

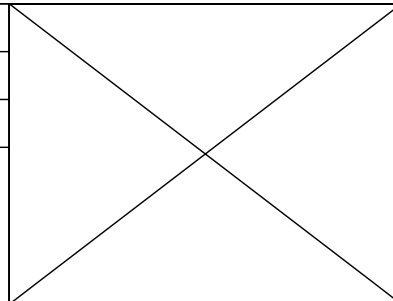

DRAWN BY LZ	Regal Beloit America, Inc.	
DATE 01-12-1994		
APPROVED BY GK	DESCRIPTION CONN DIAGRAM-EXTERNAL 3Ø-2/1 DELTA-12 LEADS	
DATE 01-14-1994		
REFERENCE	MATERIAL	PROCESS/FINISH
THIRD ANGLE PROJECTION	SIZE A	DRAWING NUMBER EE7308AA
		SHEET 1 OF 1

CERTIFICATION DATA SHEET

Model#: 326TSTDR16035 AN **WINDING#:** 3264160 NONE 1
CONN. DIAGRAM: A-EE7308AA **ASSEMBLY:** F1/F2 CAPABLE
OUTLINE: A-SS301384-1500

TYPICAL MOTOR PERFORMANCE DATA

HP	KW	SYNC. RPM	F.L. RPM	FRAME	ENCLOSURE	KVA CODE	DESIGN
50&40	37&30	1800	1775&1470	326TSC	DP	G	B

PH	Hz	VOLTS	FL AMPS	START TYPE	DUTY	INSL	S.F	AMB°C	ELEVATION
3	60/50	230/460#190/ 380	121/60.5&116/ 58	PWS(LV ONLY) & YDRUN	CONTINUOUS	B3	1.15/1.15	40	3300

FULL LOAD EFF: 94.5&94.1	3/4 LOAD EFF: 94.5	1/2 LOAD EFF: 93.6	GTD. EFF	ELEC. TYPE	NO LOAD AMPS
FULL LOAD PF: 82&82.5	3/4 LOAD PF: 79	1/2 LOAD PF: 70	94.1	SQ CAGE IND RUN	46 / 23

F.L. TORQUE	LOCKED ROTOR AMPS	L.R. TORQUE	B.D. TORQUE	F.L. RISE°C
148 LB-FT	716 / 358	283 LB-FT 191	387 LB-FT 261	50

SOUND PRESSURE @ 3 FT.	SOUND POWER	ROTOR WK^2	MAX. WK^2	SAFE STALL TIME	STARTS /HOUR	APPROX. MOTOR WGT
75 dBA	85 dBA	8.8 LB-FT^2	300 LB-FT^2	20 SEC.	2	615 LBS.

***** SUPPLEMENTAL INFORMATION *****

DE BRACKET TYPE	ODE BRACKET TYPE	MOUNT TYPE	ORIENTATION	SEVERE DUTY	HAZARDOUS LOCATION	DRIP COVER	SCREENS	PAINT
C-FACE	STANDARD	RIGID	HORIZONTAL	FALSE	NONE	FALSE	NONE	BLUE (ENAMEL)

BEARINGS		GREASE	SHAFT TYPE	SPECIAL DE	SPECIAL ODE	SHAFT MATERIAL	FRAME MATERIAL
DE	OPE						
BALL	BALL	POLYREX EM	TS	NONE	NONE	1045 HOT ROLLED (C-204)	ROLLED STEEL
6312	6311						

THERMO-PROTECTORS				THERMISTORS	CONTROL	SPACE /n HEATERS
THERMOSTATS	PROTECTORS	WDG RTDs	BRG RTDs			
NONE	NOT	NONE	NONE	NONE	FALSE	NONE VOLTS

If Inverter equals NONE, contact factory for further information

INVERTER TORQUE: NONE
INV. HP SPEED RANGE: NONE
ENCODER: NONE
NONE NONE
NONE NONE PPR
BRAKE: NONE NONE
NONE P/N NONE
NONE NONE
- FT-LB NONE V NONE Hz

*
N
O
T
E
S
*

** Subject to change without notice.

